

Hand Swager

Tie Down Model #43005

Crimps	Cable Size	Position
1	1/16	1
1	5/64	
2	3/32	2
2	7/64	
3	1/8	3
3	5/32	4
3	3/16	5

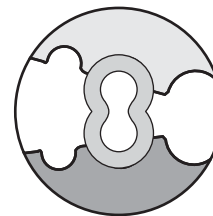
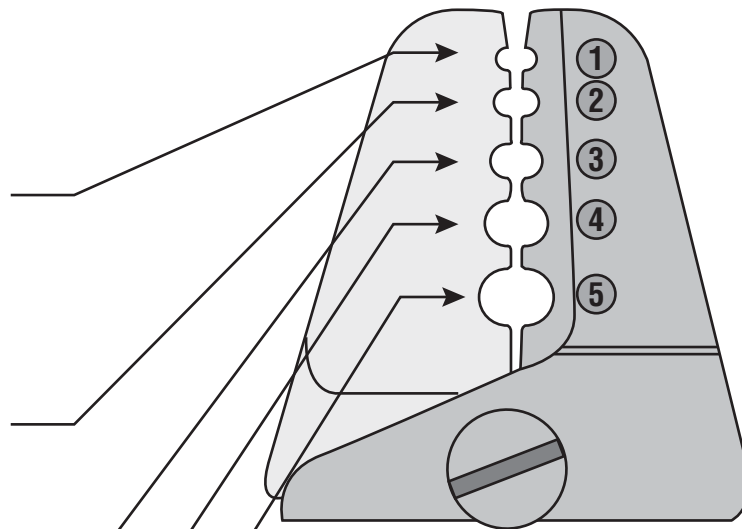

Correct

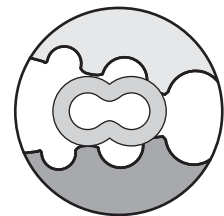

Incorrect

1. Cut cable to the required length and lace the cable through the sleeve so that the end will still protrude after crimping.
2. Properly insert sleeve into the correct cavity and line up the sleeve between the swager jaws with the long axis crosswise to the jaws.
3. Swage each sleeve the correct number of times following the swage sequence shown. Close lever handles completely until the swager slicks.
4. Lap splices can be made by 2 oval sleeves. Keep a short space between the sleeves.

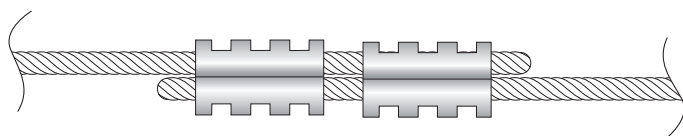
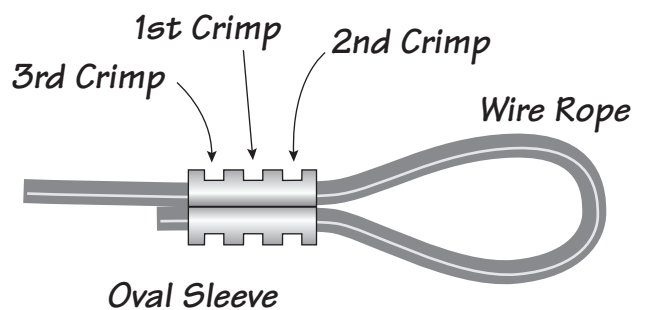
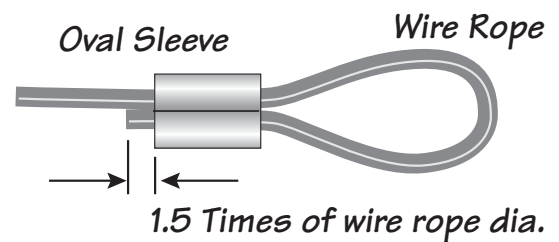

Instruction Sheet #08069

TIE DOWN ENGINEERING • 255 Villanova Drive SW • Atlanta, GA 30336
www.tiedown.com (404) 344-0000 Fax (404) 349-0401

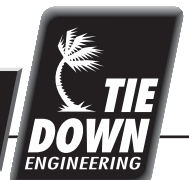

F15; 012111