



[www.tiedown.com](http://www.tiedown.com)



**MADE  
\*IN THE\*  
USA**

**Do not throw away these instructions! Read and understand these instructions before using this device.**

When used according to instruction specifications, this product meets or exceeds all applicable OSHA 1926 Subpart M, OSHA 1910, ANSI Z359.1-2007, and ANSI A10.32-2012 standards for fall protection. Applicable standards and regulations depend on the type of work being done, and also might include state-specific regulations. Consult regulatory agencies for more information on personal fall arrest systems and associated components.

**See [www.osha.gov](http://www.osha.gov) for all regulations and standards.**

# 18" Commercial Roof Anchor Installation Instructions Part #48601

**Welded Steel Galvanized Anchorage Device  
U-rod Cross Section: .625"**

**Tube: 4" Round**

**Base: 16" x 16" Square**

**Base Thickness: 3/8"**

**Overall Height: 18.37"**

**Strength Rating: 5,000 lbs**

**Capacity: 420 lbs (Worker with Tools)**

**Includes:**

**40 pcs #14 x 2.5" Type A**

**Milled Point Deck Screws**



On-line CRA  
Instructions #48601



Declaration of  
Conformity

Instruction #08309  
E1609; Rev. 9/16/20



Roofing Products Division  
605 Stonehill Drive SW,  
Atlanta, Georgia 30336  
800-241-1806 • 404-344-0000  
[www.tiedown.com](http://www.tiedown.com)



## Commercial Roof Anchor Installation Instructions Part # 48601

### WARNING WARNING WARNING WARNING



This product is part of a personal fall arrest system. The users must read and abide by the manufacturer's instructions for each element of the system. Installation of this roof anchor must be certified by a qualified person or engineering service. These directions must be given to the users of this equipment. The users must read and understand these instructions or have them explained to them before using this equipment. Manufacturer's instructions must be followed for proper use, care and maintenance of this product. Alterations or misuse of this product or failure to follow instructions, may result in serious injury or death.

#### Specifications/Definitions:

This fall arrest anchor is for single users in fall arrest or multiple users in fall restraint on a low slope roof application (4/12 pitch or less). A horizontal lifeline may be used with the Tie Down CRA's when designed by a qualified person. No more than two workers may tie off to a horizontal lifeline that is connected to a Tie Down CRA.

**Fall Restraint System** - A fall restraint system (FRS) prevents the user from falling. The system is comprised of a body harness along with an anchorage, connectors and other equipment. The components typically include a lanyard and also may include a lifeline and other devices.

**Personal Fall Arrest System (PFAS)** - Fall protection must be provided if workers are exposed to a fall of 6 feet or more to a lower level. When used properly, this will arrest a fall and prevent the worker from contacting a lower level. A PFAS consists of an anchor, a harness, and a lifeline or lanyard (usually with a deceleration device). A PFAS must be used properly to be effective. Adjust the harness to fit snugly. The D-ring attachment for the harness should be centered between the worker's shoulder blades and the leg straps should be adjusted until they are snug. Fall arrest systems must be designed and set up to prevent a worker from free falling more than 6 feet or contacting a lower level (e.g., the floor or the ground) (29 CFR 1926.502(d)(16)(iii)).

**Body Belts** - Body belts are not acceptable in a PFAS because they can cause serious injury during a fall (29 CFR 1926.502(d)).

**Anchorage** - An anchorage is a secure point of attachment for lifelines, lanyards, or deceleration devices.

**Qualified Person** - A person with an accredited degree or certification, and with extensive experience or sufficient professional standing, who is considered proficient in planning and reviewing the conformity of fall protection and rescue systems.

**Competent Person** - A person who is proficient in identifying existing and predictable fall hazards, and who has the authority to stop work in order to eliminate hazards. A highly trained and experienced person who is assigned by the employer to be responsible for all elements of a fall safety program, including, but not limited to, its regulation, management, and application.

**Authorized Person** - A person who is assigned by their employer to work around or be subject to potential or existing fall hazards.

**It is the responsibility of a qualified or competent person to supervise the job site and ensure all applicable safety regulations are complied with.**



**DANGER**

**DANGER**

**DANGER**

Maximum 1 attachment per connection point. Use of equipment in unintended applications may result in serious injury or death.

## Fall Clearance

The total fall distance is the minimum vertical distance between the worker and a lower level that is necessary to ensure that the worker avoids contact with the lower level during a fall. It is important that employers calculate this distance before work begins to ensure that the proper fall protection equipment is selected for the location. To determine the total fall distance, several factors must be taken into consideration:

- **Free Fall Distance:** The distance the worker falls before the PFAS begins to slow the fall. This distance must be 6 feet or less for a PFAS (29 CFR 1926.502(d)(16)(iii)).
- **Deceleration Distance:** The distance the lanyard stretches in order to arrest the fall. OSHA requires that this distance be no greater than 3.5 feet (29 CFR 1926.502(d)(16)(iv)), but it may be less for some PFAS equipment.
- **D-ring Shift:** How far the D-ring shifts and the harness stretches when it supports the full weight of a fallen worker, including the weight of tool belts and other attached equipment or tools. Employers typically assume this shift is 1 foot, but it can vary, depending on the equipment design and the manufacturer.
- **Back D-ring Height:** The height of the D-ring, measured as the distance between the D-ring and the sole of the worker's footwear. Employers often use a standard distance of 5 feet for this height, assuming a worker who is 6 feet tall. The D-ring height needs to be adjusted for very tall workers, and for shorter workers as well.
- **Safety Margin:** An additional distance (typically a minimum of 2 feet) to ensure that there is enough clearance between the worker and the lower level after a fall.

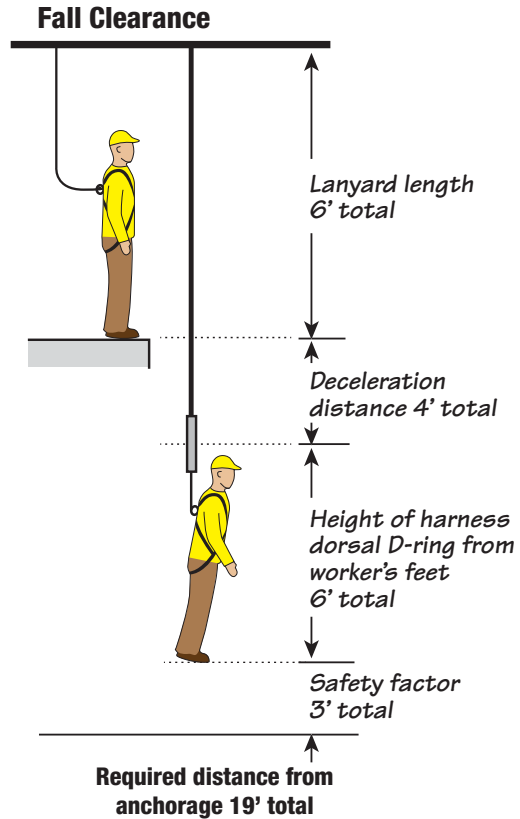

## Connections

When making connections, eliminate all possibility of roll-out. Roll-out occurs when interference between a hook and the attachment point causes the hook gate to unintentionally open and release. All connections must be selected and deemed compatible with anchors by a competent person. All connector gates must be self-closing and self-locking, and withstand minimum loads of 3,600 lbs.

## Anchor Positioning

The diagram/chart below details allowable working zones required to reduce risk of swing falls and improper side loading. ALWAYS adhere to information specified by chart.

For example, if the anchorage connector is 6' from the leading edge (A), the working distance (B) is 8' in each direction from the perpendicular, which translates to a 53° working angle.

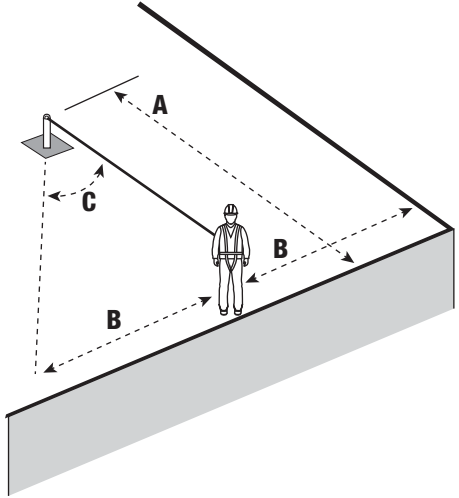

Anchor Distance From Leading Edge (A)	Working Distance Along Roof Edge (Either Direction) (B)	Working Angle From Perpendicular (C)
6'	8'	53°
10'	9' - 9"	45°
15'	11' - 7"	38°
20'	13' - 3"	33°
25'	14' - 6"	30°
30'	16'	28°
35'	17' - 2"	26°
40'	18' - 3"	24°
45'	19' - 4"	23°
50'	19' - 10"	21°
55'	21' - 4"	21°
60'	22' - 3"	21°

# Commercial Roof Anchor Installation Instructions

Part # 48601



## RECOMMENDED INSTALLATION:

Roof Anchors must be installed and spaced a maximum of 20 ft. apart. Installation around the perimeter of the leading edge areas is recommended to ensure compliance and allow the user to easily switch from anchor to anchor. Recommended spacing is between 6 and 10 ft. from edge of roof. Do not install the roof anchor on unsupported roof structures such as overhangs or inadequately secured decking.

**1. ANCHORAGE:** Select an anchorage point that is structurally secure and capable of supporting the required loads, see below installation suggestions.

**2. CONSIDERATIONS:** Personal fall arrest systems must be rigged to limit any free fall to a maximum of 6 ft. Avoid working above your anchorage level since an increased free fall distance will result. Avoid working where your line may cross or tangle with that of another worker or another object. Do not allow the lifeline to pass under arms or between legs. Never clamp, knot or otherwise prevent the lifeline from retracting or being taut, avoid slack line.

**3. FALL DISTANCE:** Should a fall occur, there must be sufficient clearance in the fall area to arrest the fall before striking the ground or other object. The total fall distance is the distance measured from the onset of a fall to the point where the fall is arrested. A number of factors can influence the total fall distance including; user's weight, anchorage location relative to the fall (swing fall), body support with sliding D-ring, and the type of fall arrest equipment you attach to the roof anchor. For specific clearance requirements read and follow the manufacturer's instructions for your fall arrest equipment.

**4. SWING FALLS:** Swing falls occur when the anchorage point is not directly above the point where a fall occurs. The force of striking an object while swinging (horizontal speed of the user due to the pendulum affect) can be great and may cause serious injury. Swing falls can be minimized by working as directly below the anchorage point as possible. In a swing fall situation, the total vertical fall distance of the user will be greater than if the user had fallen vertically directly below the anchorage point. The user must therefore account for an increase in the total free fall distance and the area needed to safely arrest the fall. A commonly followed guideline is not to extend your work zone over 30° from the anchorage point.

**5. SHARP EDGES:** Avoid working where the connecting subsystem or other system components will be in contact with, or abrade against unprotected sharp edges. If working with this equipment near sharp edges is unavoidable, protection against cutting must be provided by using a heavy pad or other means over the exposed sharp edge. Refer to ANSI Z359.14 when using CRAB in combination with Leading Edge Retractable

**6. RESCUE:** The user (employer) must have a rescue plan, rehearse that rescue plan with employees, and continually have the means at hand to implement it. All personnel must be prepared should a fall occur.

**7. AFTER A FALL:** Any equipment which has been subjected to impact loading must be removed immediately from service and shall not be used again for employee protection until inspected and determined by a qualified person to be undamaged and suitable for reuse.

**PRIOR TO EACH USE:**

Personal fall arrest systems and components shall be inspected prior to each use for wear, damage, and other deterioration. Defective components must be removed from service. Personal fall arrest systems shall not be attached to guardrail systems or hoists.

**HORIZONTAL LIFELINES:**

Horizontal lifelines shall be designed, installed, and used under the supervision of a qualified person as part of a complete personal fall restraint system.

**INSTALLATION OF THE ROOF ANCHOR**

The roof structure coupled with the fastening of the roof anchor to the roof structure must meet the minimum strength of 5,000 lbs. A professional engineer or other such qualified person must certify that the anchorage meets this requirement.

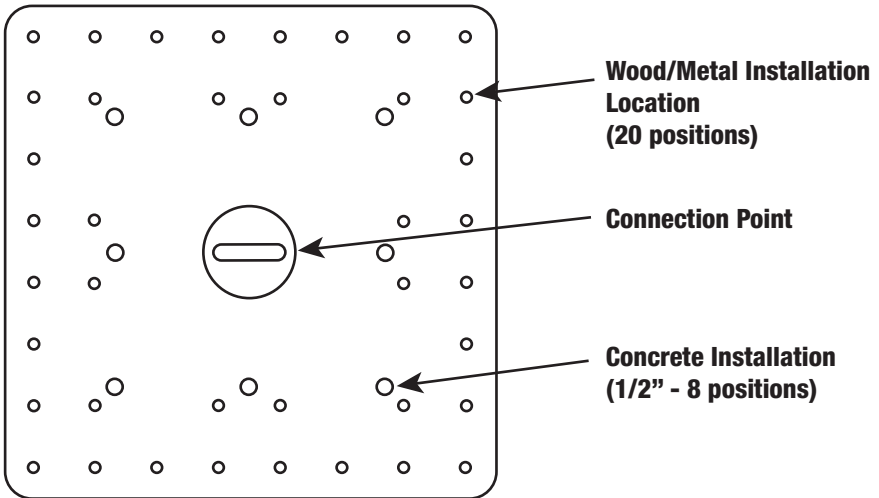

## WOOD DECKING

The anchor must be installed in the center of a plywood sheet that is 48" x 48" and is secured to at least 3 top trusses see fig. 1.

Minimum thickness of plywood decking is 1/2" with 3/4" backer, see fig. 2. The deck sheathing must be secured at all perimeter edges, 8" on center using deck screws. Secure a sheet of 3/4" x 48" plywood reinforcement board as shown in fig. 1 & 2, cut to fit between the inside width of the truss spacing. Attach the reinforcement board to the deck sheathing using the same 8" on center and screws. Anchor Fastening Specification: Attach the anchor using at least 40 -2.5"x #14 hex head screws. The fasteners must penetrate through the reinforcement board. A visual inspection should be taken to verify that the fasteners are installed through the board.

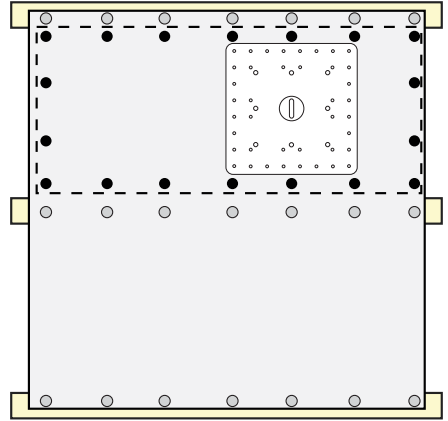
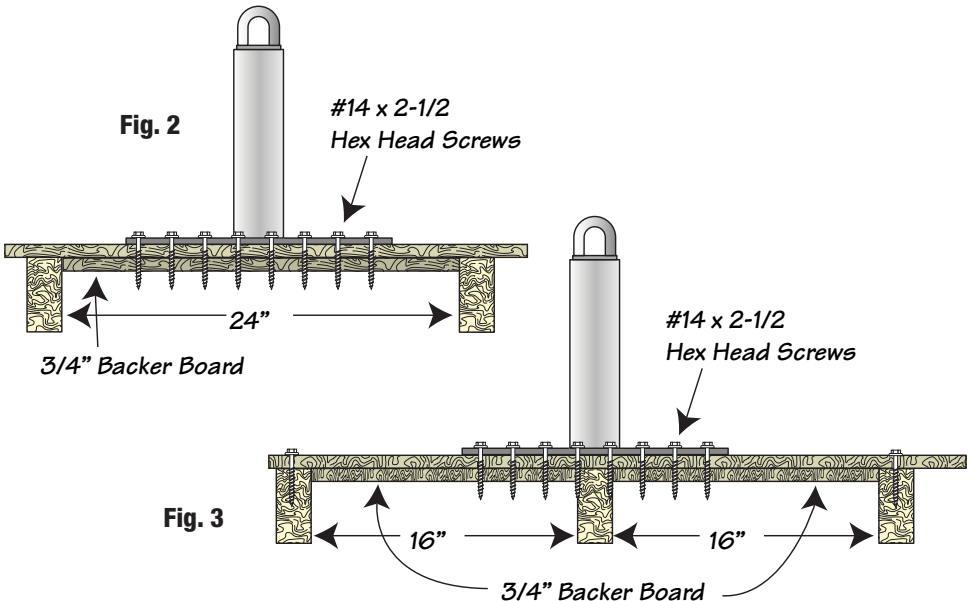

Fig. 1

For trusses with 24" spacing, center the anchor as shown in fig. 2. For trusses less than 24", two reinforcement boards must be used and the anchor centered over the truss as shown in fig. 3. Additional screws for reinforcing decking not supplied by Tie Down. All anchorage methods must be inspected and certified by a professional engineer or qualified person.





## CORRUGATED STEEL ROOF DECKING

The roof structure with steel decking that the roof anchor is to be installed onto must meet the minimum strength of 5,000 lbs. A professional engineer or qualified person must certify that the anchorage meets this requirement. The steel decking material must be a minimum of 20 gauge. Additional structural members may be needed to allow the anchor to be securely attached to the primary roof structure. Align the anchor base plate fastener holes over the raised channel of the steel decking as shown in fig. 4. Attach the anchor to the metal deck using 40 #14 x 2.5" self tapping hex head screws. Do not over tighten fasteners. Steel Decking less than 20 gauge: Attach a second layer of metal decking 36" x 36" (915 x 915mm) as shown in fig. 5, over the primary metal decking. Attach the second layer to the primary using #14 deck screws, 8" (204mm) on center through all raised channels of the metal decking.

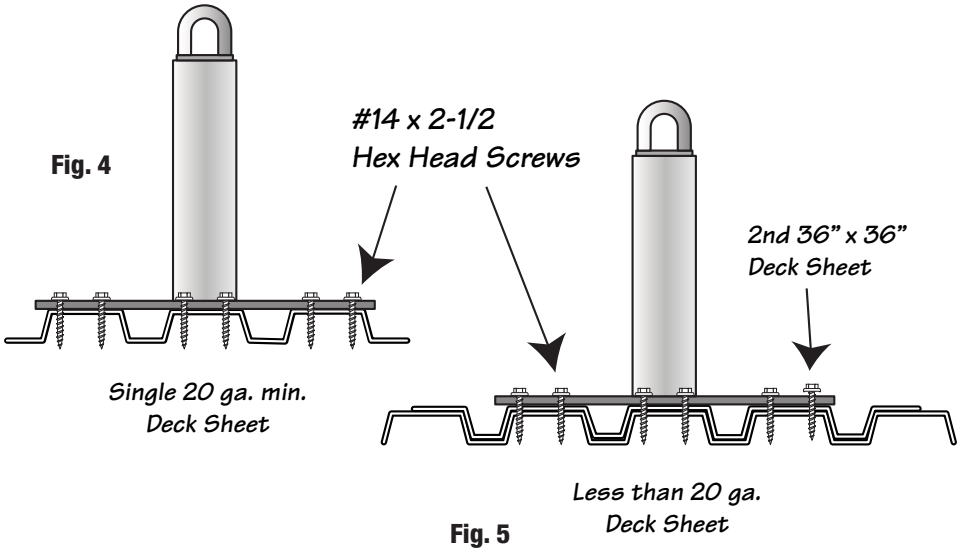

## Concrete

The concrete that the roof anchor is to be installed onto must have a minimum thickness of 4" and be rated at 2,000 psi. min. Use 8 - 1/2" wedge anchors (not supplied) rated at 6,000 lbs, to attach and align as shown in fig. 6. The concrete must be fully cured to withstand the required 5,000 lb. load before using.

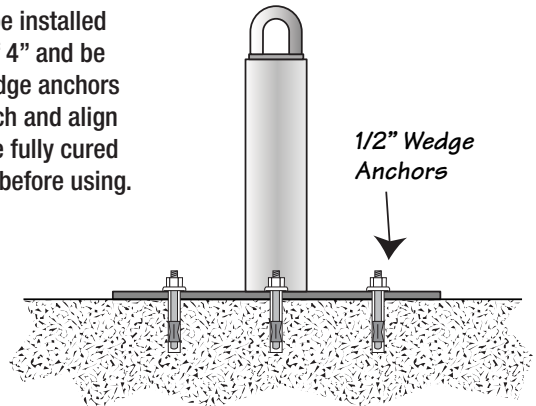

**WARNING****WARNING****WARNING****WARNING**

Failure to understand and comply with safety regulations may result in serious injury or death. Regulations included herein are not all-inclusive, are for reference only, and are not intended to replace a competent person's judgment or knowledge of federal or state standards.

## **Safety Information - Do not alter equipment. Do not misuse equipment.**

Workplace conditions, including, but not limited to, flame, corrosive chemicals, electrical shock, sharp objects, machinery, abrasive substances, weather conditions, and uneven surfaces, must be assessed by a competent person before fall protection equipment is selected.

The analysis of the workplace must anticipate where workers will be performing their duties, the routes they will take to reach their work, and the potential and existing fall hazards they may be exposed to. Fall protection equipment must be chosen by a competent person. Selections must account for all potential hazardous workplace conditions. All fall protection equipment should be purchased new and in an unused condition.

Fall protection systems must be designed in a manner compliant with all federal, state, and safety regulations. Forces applied to anchors must be calculated by a competent person. Unless explicitly stated otherwise, the maximum allowable free fall distance for lanyards must not exceed 6'. No free fall allowed for non-LE SRLs. Class A SRLs must arrest falls within 24"; Class B SRLs must arrest falls within 54".

Harnesses and connectors selected must be compliant with manufacturer's instructions, and must be of compatible size and configuration. Snap hooks, carabiners, and other connectors must be selected and applied in a compatible fashion. All risk of disengagement must be eliminated. All snap hooks and carabiners must be self-locking and self-closing, and must never be connected to each other.

A pre-planned rescue procedure in the case of a fall is required. The rescue plan must be project-specific. The rescue plan must allow for employees to rescue themselves, or provide an alternative means for their prompt rescue. Store rescue equipment in an easily accessible and clearly marked area.

Training of Authorized Persons to correctly erect, disassemble, inspect, maintain, store, and use equipment must be provided by a Competent Person. Training must include the ability to recognize fall hazards, minimize the likelihood of fall hazards, and the correct use of personal fall arrest systems.

Equipment subjected to forces of fall arrest must immediately be removed from use. Age, fitness, and health conditions can seriously affect the worker should a fall occur. Consult a doctor if there is any reason to doubt a user's ability to withstand and safely absorb fall arrest forces or perform set-up of equipment. Pregnant women and minors must not use this equipment. Physical harm may still occur even if fall safety equipment functions correctly. Sustained post-fall suspension may result in serious injury or death. Use trauma relief straps to reduce the effects of suspension trauma.

## WARNING and Inspection Labels

The Competent Person must sign their initials in the box corresponding to the month and year the inspection took place. If either labels are damaged or unreadable please contact Tie Down for replacements.

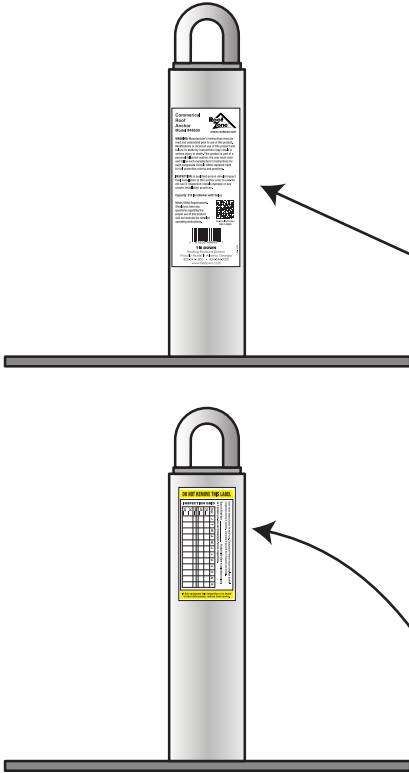

## Commerical Roof Anchor Model #48601

**WARNING:** Manufacturer's instructions must be read and understood prior to use of this product. Modifications or incorrect use of this product and failure to abide by instructions may result in serious injury or death. This product is part of a personal fall arrest system, the user must read and follow each manufacturer's instructions for each component. Consult OSHA standard 1926 for fall protection criteria and practices.

**INSPECTION:** A qualified person should inspect final installation of this anchor prior to use. Do not use if inspection reveals damage or any unsafe installation practices.

**Capacity: 310 lbs (Worker with Tools)**

Meets OSHA Requirements.  
Should you have any questions regarding the proper use of this product visit our web site for detailed operating instructions.



On-Line Instruction  
CRA # 48601



**TIE DOWN**

Roofing Products Division  
Proudly Made In Atlanta, Georgia  
800-241-1806 • 404-344-0000  
www.tiedown.com

Rev. 1/19

**DO NOT REMOVE THIS LABEL**

User must inspect prior to each use. Competent Person must complete formal inspection every 6 months. Competent person to inspect and initial.

Date of First Use: \_\_\_\_\_ Product life time is unlimited as long as it passes pre-use and Competent Person inspections.

**INSPECTION GRID**

Year	J	F	M	A	M	J	J	A	S	O	N	D
20__												
20__												
20__												
20__												
20__												

If this equipment fails inspection or is found to have deficiencies, remove from service.

## Maintenance, Cleaning, and Storage

If anchor fails inspection in any way, immediately remove it from service, and contact TIE DOWN to inquire about its return or repair. Cleaning after use is important for maintaining the safety and longevity of this anchor. Remove all dirt, corrosives, and contaminants from the anchor before and after each use. NEVER clean anchors with corrosive substances. When not in use, store equipment where it will not be affected by heat, light, excessive moisture, chemicals, or other degrading elements.

## Inspection

Prior to EACH use, inspect all anchors for deficiencies, including, but not limited to, corrosion, deformation, pits, burrs, rough surfaces, sharp edges, cracking, rust, paint buildup, excessive heating, alteration, and missing or illegible labels. IMMEDIATELY remove any anchor from service if defects or damage are found, or if exposed to forces of fall arrest.

Ensure that applicable work area is free of all damage, including, but not limited to, debris, rot, rust, decay, cracking, and hazardous materials. Ensure that selected work area will support the application-specific minimum loads set forth in this instruction manual. Work area MUST be stable. At least every 6 months, a competent person other than the user must inspect each anchor. The Competent Person must sign their initials in the box corresponding to the month and year the inspection took place.

## INSPECTION GRID

**INSPECT BEFORE EACH USE.** A competent person must complete a formal inspection every 6 months and document below with initials. The life of this roofing device is unlimited as long as a competent person inspects and passes equipment as in good order every 6 months.

Date of First Use: \_\_\_\_\_

<b>Year</b>														
<b>Month</b>														
<b>Date</b>														
<b>Initials</b>														

If this equipment fails inspection or is found to have deficiencies, remove from service. Deficiencies include, but are not limited to deformation, corrosion, burrs, sharp edges, cracking, rust, pits, excessive heating, paint buildup, alteration, damaged parts and missing or unreadable labels.



MANUFACTURING INGENUITY

Roofing Products Division  
605 Stonehill Drive SW  
Atlanta, Georgia 30336  
800-241-1806 • 404-344-0000

www.tiedown.com  
ISO 9001:2015 Certification  
Intellectual property of TIE DOWN Inc.  
©2018 TIE DOWN, Inc.  
Instruction #08309 (E1609 Rev. 9/16/20)