

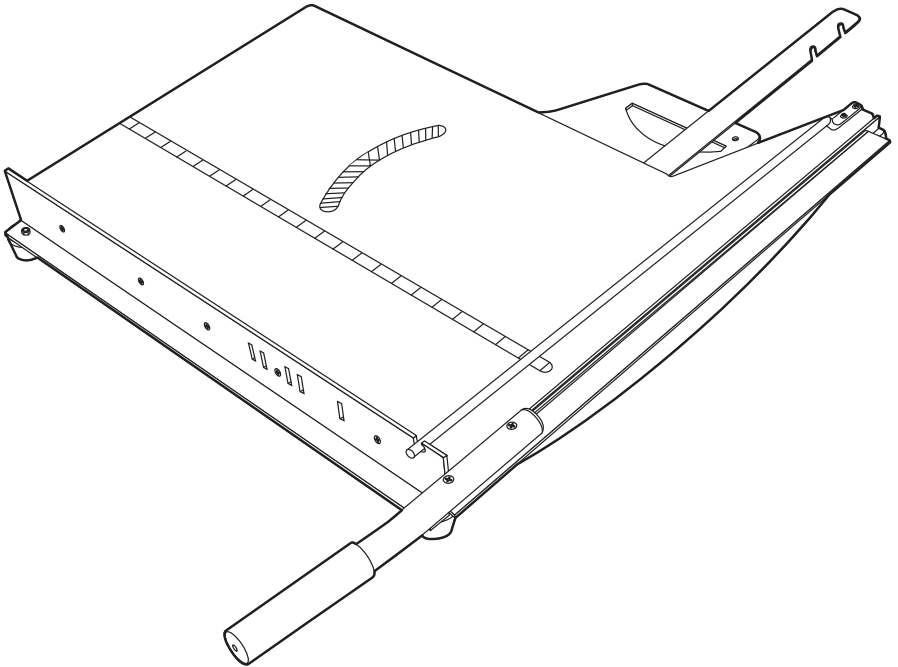

Shingle Shaper

Part #13806



Safety First

Always keep hands and fingers away from blade guard when using. Do not use Shingle Shaper when the guard is not installed. Always secure cutting blade in the closed position using locking pin when not in use. Keep out of reach of children. When securing to roof, use hook bracket for roof pitches steeper than 6/12.

Instruction Sheet E1363 Rev. 11/4/19

Shingle Shaper

Part #13806



Assembly Instructions

Attach handle to the blade arm using a Phillips head screw driver. Tighten two screws through the handle to the blade arm.

Cutting Methods:

- Cut shingles with the granules up.
- Hold shingles with free hand while cutting, this prevents the shingle from moving during cutting procedure.
- Depending on shingle content and temperature, your method of cutting may need to change. For instance, faster, slower, more or less pressure, or chopping action.
- When cutting Hips and valleys, position the laminated area nearest to the pivot point.

Cutting

First Row Starters 5", 7", 7-5/8" 9" or 9-1/2"

When cutting first row starters, position ripping fence to one of the above sizes. Pivot pin should be in the down position. Slide the end with spring into slots at the top of the cutter first, then pull the fence compressing the spring to position into the bottom slots. Lift up the orange guard and slide shingle under and carefully toward the top of the blade. Make several chops of the blade and push the shingle straight along the fence, chopping until the shingle is cut.

Valley and Hip Cuts

Pitch lines are in the center of the Shingle Shaper, these relate to the roof pitch 4 is equivalent to a 4/12 valley. See Figure 1 for cutting left side valley and figure 2 for a right side valley.

Due to the cut being greater than 20", a second cut will be required. By pushing the pivot pin down, the shingle then can be moved allowing the finishing cut. Large shingles can be done as shown in Figure 1 with the pivot pin up. Shingles may be turned over to accomplish the above cuts.

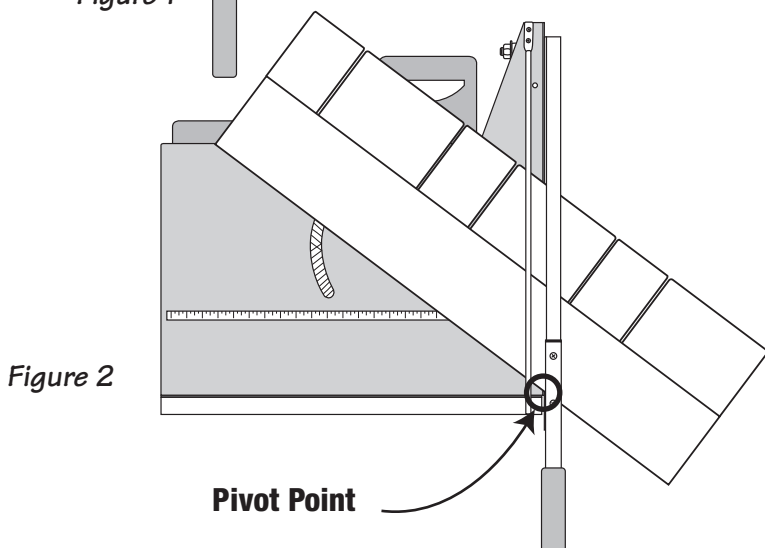
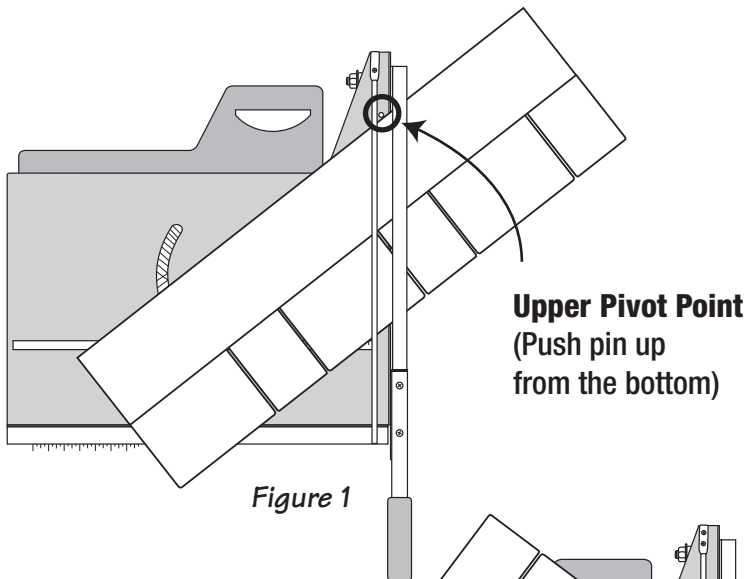

Cleaning and Maintenance

Blade and table surface should be cleaned periodically to remove any material build up which can affect the quality of the cuts. A cleaning liquid may be used.

Grease may be applied occasionally to the blade pivot joint between the two cutting edges. This will help reduce wear and tear on the blades.

In hotter seasons, wax or silicone can be used on the cutting edges and table top to reduce tar build up.

Blade Information - Replacement Blade #13807

This blade is made out of carbon steel and should not need sharpening. The blade is reversible (front to back) and the cutting edge is a flat 90°. If sharpening becomes necessary make sure to sharpen at 90 degrees. Replacement blades are available.

Blade Replacement Instructions

1. Flip the Single Shaper upside down.
2. Using a set of pliers and a 18mm wrench remove the bolt that holds the blade/tension spring.
3. Remove washers, spring and bolt.
4. Place the blade arm on it side.
5. Using a Phillips head screwdriver and a 7mm wrench, remove 5 sets of screws along the cutting blade.
6. Flip the blade 180° or replace the old blade with the a new one (Part #13807).
7. Replace the 5 sets of screws with lock washers and nyloc nuts on the cutting blade.
8. Reassemble the Shingle Shaper according to the diagram below.
9. Tighten the spring nut with enough tension as to effety cut shingles.

