

Xi2 Foundation System Asphalt Installation Instructions By Tie Down Engineering



These plans and specifications meet the requirements of the IBC 2009, 90 mph. Exposure C, ASCE 7-05, IRC and HUD Wind loads.



**Steel Pier Asphalt System
(Pad, Asphalt Spikes and Brackets)
Part #59616**

Requirements

- Designed for I Beam or Perimeter Frame main rails.
- Vertical anchor ties that are unique to design may be required by the manufacturer. These locations may include shear walls, marriage line ridge beam support posts, and rim plates. The longitudinal component of the Xi2 System replaces end frame ties. Check manufacturer's set-up requirements.
- Maximum Pier Height 48".
- Steel piers must be fastened to the I-beam with clamps provided with steel pier.
- Systems must be installed with Xi2 lateral and longitudinal braces, each sold separately.
- Place systems as shown on page 3 of 4. For standard I-beams, place systems as evenly as possible with the corner systems no more than 10' from the end of the unit, and additional systems at the approximate midpoint of the unit.
- Longitudinal strut angles need to be no more than 50 degrees and no less than 25 degrees.
- The Xi2 system is installed under one of the pier locations required by the home manufacturers set-up instructions. No other base pad is needed at this location.
- The asphalt must be a minimum of 1-1/2 in. thick and the center of the pads must be a minimum of 12 in. from the nearest edge of the asphalt.

HUD Requirements

- Maximum vertical projection at sidewall is 9' (wall and eave). Higher walls may be used when design loads are adjusted accordingly.
- For roof slopes up to 20 degrees, (4.37" in 12" Pitch)
- Wind Zones II & III require sidewall anchors for uplift. Check manufacturers requirements.

IBC, IRC Requirements

- Maximum wall height 14', unless design loads adjusted accordingly.
- Designed for roof slope less than 10 degrees.

Standard I-Beam Installation

1. Identify the number of systems needed using the chart provided (see page 4).
2. Identify the location where the systems will be installed.
3. Place pad centered under the beam with the with the flat lip side of the pad facing outward.
4. Mark spots where the rod is to be installed through pad and bracket and remove pad. For standard outrigger I-beams; brackets go in the center slots. (3 rods per pad as symmetrical as possible).
5. Using a hammer drill, drill a 3/4" hole approximately 6" into the asphalt at the locations where the lateral and longitudinal strut brackets, plus 3rd rod are to be attached. Slide washer onto rod to the crimp spot.
6. Attach the lateral strut bracket to the center of the pad facing the other I-beam by driving stake through the bracket and pad into the asphalt.
7. Attach the longitudinal strut bracket to the end of the pad closest to the inside of the home through the center hole by driving the stake through the bracket and pad into the asphalt.
8. Drive a stake in the opposite end of the pad so there are 3 stakes as symmetrical as possible.
9. Attach the lateral strut to the center bracket so the end of the strut reaches across to the opposite I-beam and attach the flag end to the beam with the J bolt over the top of the beam using nuts and bolts provided.
10. Place steel pier on pad and adjust pier top so it is tight under the beam.
11. Install longitudinal frame clamps to I-beam on inside of block/pier. Do not tighten at this time.
12. Size longitudinal struts to assure they are no more than 50 degrees and no less than 25 degrees, (may be cut to length).
13. Attach one end of longitudinal strut to bracket in end of pad and other end to the Longitudinal frame clamp using nuts and bolts provided.
14. Tighten all nuts and bolts on struts and beam clamps at this time.

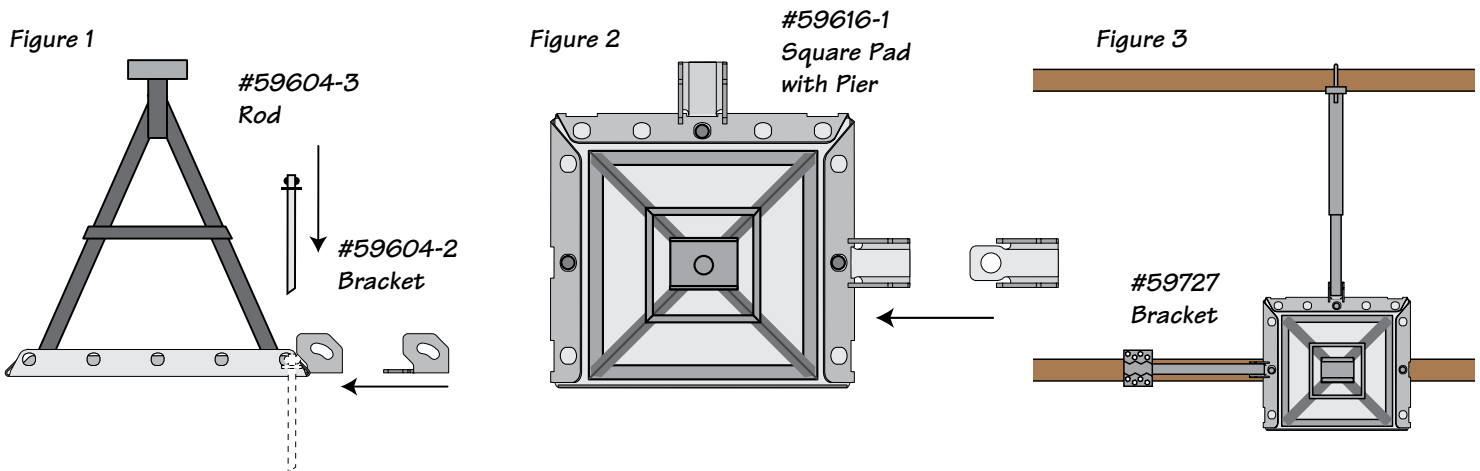

Perimeter Frame Installation

1. Identify the number of systems needed using the chart provided (see page 4).
2. Identify the location where the systems will be installed.
3. Place pad on the corner of unit with the long flat lip side facing outward on the longer side.
4. Mark spots where the rods are to be installed through pad and bracket and remove pad. For perimeter beam sets; brackets go in the corner slots. (3 rods per pad as symmetrical as possible).
5. Using a hammer drill, drill a 3/4" hole approximately 6" into the asphalt at the locations where the lateral and longitudinal strut brackets, plus 3rd rod are to be attached. Slide washer on rod to crimp spot.
6. Attach the lateral strut bracket to the end of the pad facing across the end of the unit by driving rod through the bracket and into the asphalt.
7. Attach the longitudinal strut bracket to the end of the pad closest to the inside of the home using the outside hole under the beam through the bracket and into the asphalt.
8. Drive the remaining rod into pad so there are 3 rods as symmetrical as possible

I Beam Frame Installation

9. Install longitudinal frame clamps to I-beam on inside of block/pier. Do not tighten at this time.

C or CR Frame Installation

9. Attach frame brackets to beam by drilling two 1/2" holes through the beam on the bottom through bracket. Attach to beams with nuts and bolts provided.

Perimeter Frame Installation (Continued)

10. Place steel pier on pad and adjust pier top so it is tight under the beam.
11. Size struts to assure they are no more than 50 degrees and no less than 25 degrees, (may be cut to length).
12. Attach one end of each strut to the bracket in the pad and the other end to the frame brackets with nuts and bolts provided and tighten all bolts on struts and brackets.

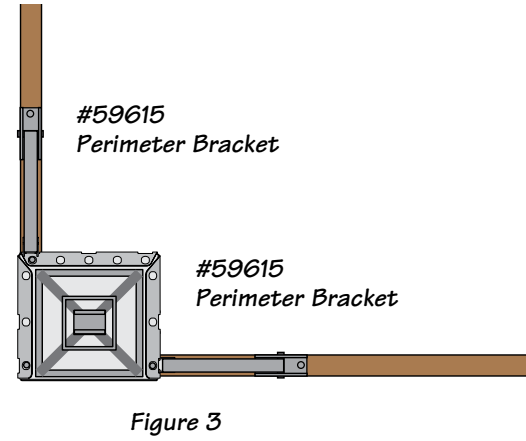
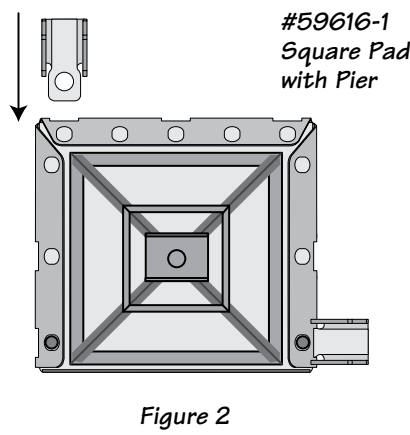
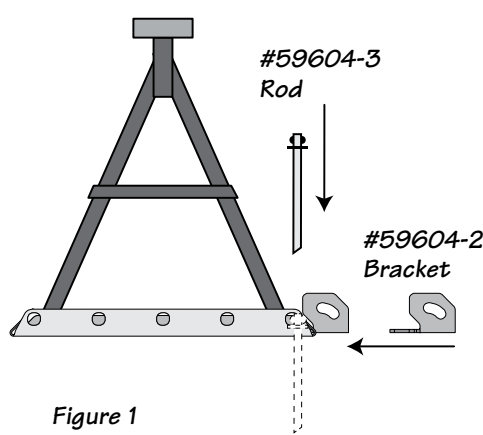

Xi2 Standard I-Beam Pier Placement

#59367 Asphalt Anchor* for HUD Units



Extra System Placement (When Needed)

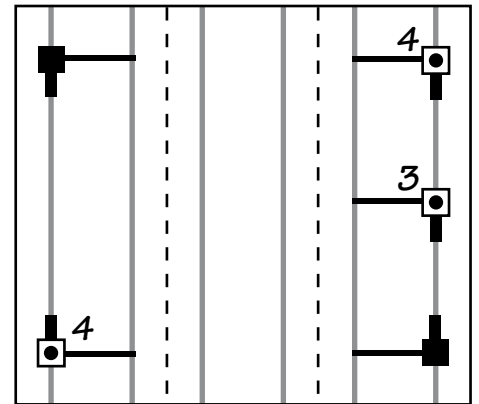
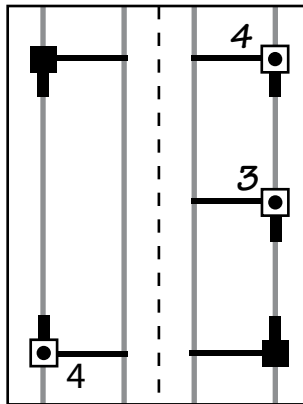
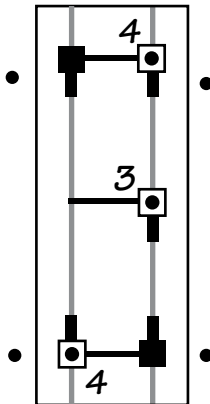

Xi2 Perimeter Pier Placement

#59367 Asphalt Anchor* for HUD Units



Extra System Placement (When needed on any open corner)

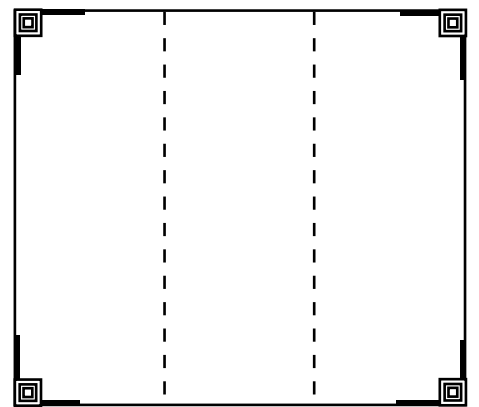
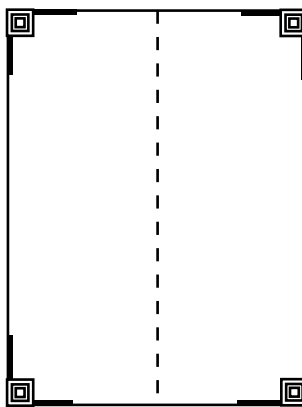
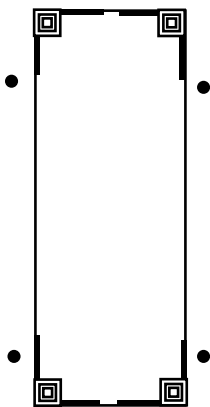

HUD Number of Xi2 Systems Required

Xi2 Asphalt System consists of Lateral and Longitudinal Stabilization.

Wind Zone I		Wind Zone II		Wind Zone III	
0 –70' Box	2 Systems	0 –40' Box	2 Systems	0 – 32' Box	2 Systems
71'–80'	3 Systems	41'– 60'	3 Systems	33'-48'	3 Systems
Over 80'	4 Systems	61'- 80'	4 Systems	49'-64'	4 Systems
		Over 80'	5 Systems	65'-80'	5 Systems
				Over 80'	6 Systems

- A. Place Systems approximately 10 ft. or less from the ends of the unit.
 - B. 2 Systems-place at diagonally opposite corners.
 - C. 3 Systems-place system at the approx. midpoint on either side.
 - D. 4 Systems-place one system on each corner.
 - E. 5 Systems-place system at the approx. midpoint on either side.
 - F. 6 Systems-place one additional system at the approx. midpoint across from 5th system.
- ** Asphalt Anchor with Vertical Strap or Frame Tie within 10' of all 4 corners of Single Section units.
 **59367 Asphalt Anchor For HUD units

IBC 2009, 90 mph, Exposure C, ASCE 7-05 Number of Xi2 Systems Required

Xi2 Asphalt System consists of Lateral and Longitudinal Stabilization.

Up to 12'	0-64' Box	3 Systems	Up to 14'	0-60' Box	3 Systems
Wall Height	Over 64'– 80'	4 systems	Wall Height	Over 60' – 80'	4 Systems

Standard

- A. Place Systems approximately 10 ft. or less from the ends of the unit.
- B. 3 Systems - place 3rd system at the approx. midpoint on either side.
- C. 4 Systems - place one system at each corner.

Perimeter

- A. All units are installed on the corners.
- B. 4 Systems - place one system on each corner.

NOTE: Wall heights are the eave height for a building without solid skirting. If solid skirting is installed, add the skirting height and use that sum as the wall height. Tear away skirting such as vinyl is not considered solid skirting. Diagram represents single section up to 16' width, double section up to 32' width, and triple section up to 48' width. For multiple section units, determine the number of systems based on each group of 3 modules, with the remainder based on a double or single section (without anchors).

