



# Turbo Lube Hubs Oil Bath Lubrication

Simple is best. Especially when it comes to wheel bearing maintenance. That's why Tie Down has developed Turbo Lube, the hub bearing lubrication system that provides continuous protection.

Turbo Lube oil bath lubricating system rotates individual roller bearings over four times through oil for each wheel revolution keeping your hub and bearings cooler, reducing wear and friction, and actually increasing tow vehicle mileage. The unique see through threaded oil cap assures a leak proof seal and let's you know if your bearings have adequate lubrication for the next long run.

The Turbo Lube system provides extended bearing life by thoroughly distributing oil and eliminates the need to disassemble the hubs and repack the wheel bearings. Simply put, that means peace of mind for you.

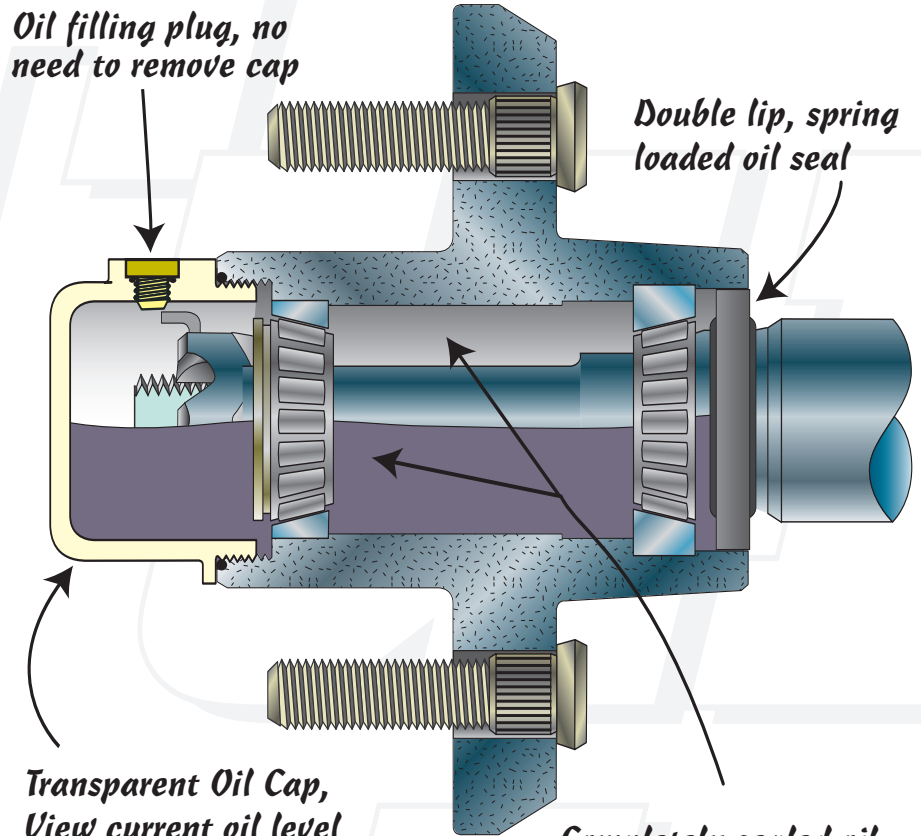

*Completely sealed oil reservoir chamber permits maximum lubrication*

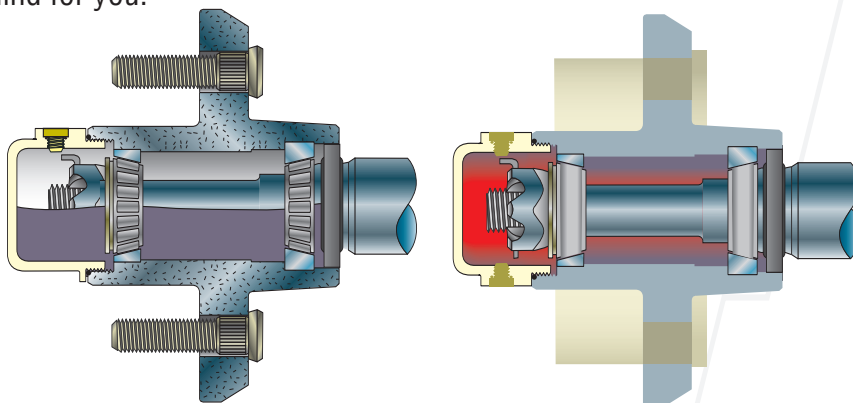

As your speed increases, the oil inside the Turbo Lube Hub uses the centrifugal force to completely lubricate all the bearings.

# Consumer Packaged Turbo Lube Hub Kits

Convenient clamshell packaging has a molded in hand grip, and is sealed for easy storage. Bright four color printing for fast and easy recognition within the Long Run Product Line. Kits includes: hub, transparent oil cap, oil fill plug with O-ring, lug nuts, front and rear bearings, rear seal, cotter pin and complete operating instructions



MAATS Innovation Award Winner:  
Turbo Lube Oil Bath Hubs



Display Stand: 8.5"W x 9.5"H x 7"D  
Complete with 4-color graphics & hub.  
Part Number #94100

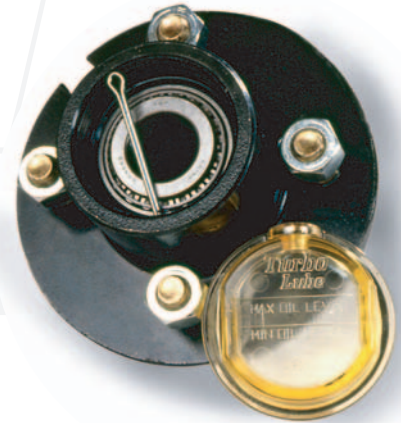

Description	Part #
4 Stud Hub Kit* (1250#) 1" inner & outer bearings, with lug nuts	81018
4 Stud Hub Kit* (1350#) 1-1/16" inner & outer bearings, with lug nuts	81038
5 Stud Hub Kit* (1250#) 1" inner & outer bearings, with lug nuts	81023
5 Stud Hub Kit* (1350#) 1-1/16" inner & outer bearings, with lug nuts	81043
5 Stud UHI Hub Kit (1750#) 1-1/16" inner & 1-3/8" outer bearings for tapered spindles, with lug nuts	81048
Turbo Lube Display Stand (w/hub)	94100
Turbo Lube Display Stand (without hub)	48390

\*NOTE: Fits all wheels with a center hole of 2.75" or larger.  
May not fit all 8" to 13" wheels